



Soundweb™

Harnessing the power of
programmable DSP with
flexible control

Clubs
Hotels

Venues

Theatres

Law Courts

Theme Parks

Sports Stadia

Cruise Liners

Paging Systems

Leisure Centres

Function Rooms

Teleconferencing

Corporate Offices

Distance Learning

Houses of Worship

Convention Centres

Conference Centres

Live Sound Production

Performing Arts Centres

Universities, Colleges and Schools

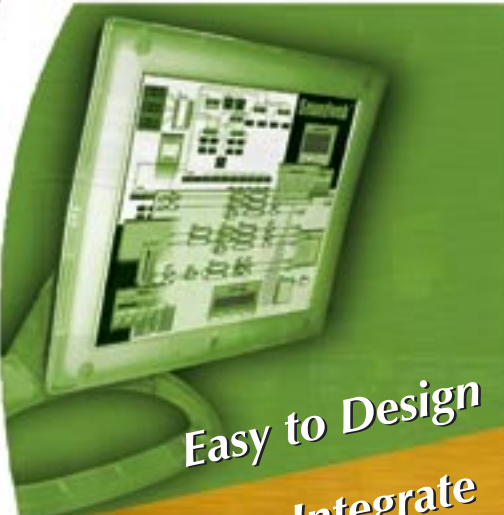

Easy to Design

Easy to Integrate

Easy to Install

Easy to Operate



The advent of programmable DSP systems has dramatically changed the way audio systems are installed. Tedious changeovers between sessions with large amounts of equipment to re-program and re-patch are a thing of the past, and gone are the large racks full of audio processing gear and complicated multi-way cabling between areas.

Soundweb™

A free design programmable DSP system means that you can have virtually any audio system design.

It means that you can change what your audio system is doing according to the type of event you are holding, just by recalling a preset.

It means that you can easily and quickly add more processing to the system without increasing the hardware budget.

It means that any specification changes during or after the design phase can easily be implemented.

But while there are many DSP systems to choose from, Soundweb has a complete system approach unrivalled by virtually any manufacturer. A client base that includes the World's premier theme bar and Hotel chains is testimony to BSS's total approach to providing a universal system.

Soundweb is a set of audio processing units that can be linked by a digital communications network. The units are completely flexible; you program the signal paths and block diagram of the processing using a PC, choosing the processing blocks from an extensive library. Soundweb units can be fitted with microphone pre-amplifiers, so you can create almost any audio system, including all of the processing, all the way from microphone to power amplifier.

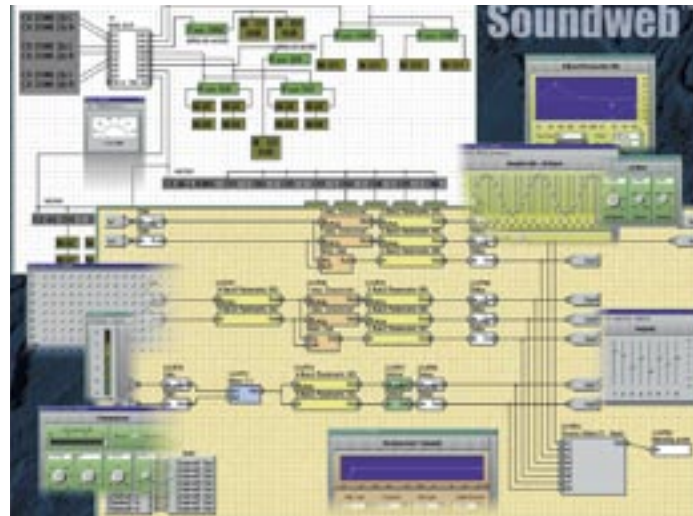

FEATURES

- ❑ Distributed processing, networking and DSP means that hardware can be installed where it's needed.
- ❑ Proprietary networking that requires no external networking hardware or setups.
- ❑ Network carries both control data and 8 channels of bi-directional 24-bit 48kHz digital audio for pristine audio performance throughout the system.
- ❑ Proprietary and simple networking needs no IT skills to implement.
- ❑ High network tolerance and stability.
- ❑ Very low network latency makes Soundweb ideal for use in Live Event and Theatre applications.
- ❑ A variety of control options and interfaces mean that you can give your clients the exact level of control they need.
- ❑ Systems can easily be expanded or updated.

What makes Soundweb so special?

Flexibility, easy expansion, digital audio networking over long distances, quality, heritage, simplicity of control, security and power — Soundweb by BSS Audio probably has more than any other digital matrix or processing system.

Pristine Audio Quality

Vitaly, you can be sure of the highest audio quality, with Soundweb's 24-bit internal processing, headroom management, and advanced A/D and D/A conversion.

Importantly for your peace of mind, any Soundweb system can easily be expanded with further devices at a later date. Start-up costs for small systems are low, while sophisticated large-scale installations are cost-effective and very powerful.



Easy to Design

All your audio system design is done offline (even while travelling on an aeroplane, if you like!). Using BSS's own Soundweb Designer software, you can build your system, design the processing path, set initial gains, routing, equalisation and dynamics processing. When you're ready, connect the PC to one device in the system, and upload.

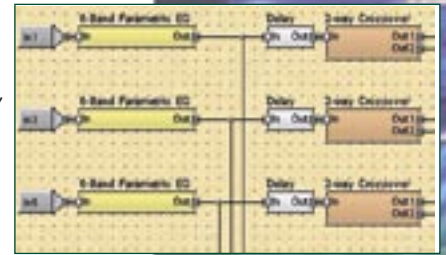

Soundweb offers a library of DSP processing objects that contains most of the commonly used audio processing functions. These include: automatic mic mixing, levelling, mixing, equalisation, filtering, crossovers, delay, and dynamics processing, as well as utility functions such as tone generators and meters, and macros allow you to create your own proprietary DSP objects.



Easy to Install

Soundweb's audio and control network runs over standard computer Cat 5 cable, so installation is both low cost and simple. The network runs up to 300 metres/1,000 feet between devices with no degradation in audio quality.

Each Soundweb DSP device is totally self-contained, and the network means that you can install devices locally to their amplifier racks rather than in any one centralised location, and the low network latency (possibly the lowest in use) means that signal delays are minimal.

Each Cat 5 cable carries 8 channels of bi-directional 48kHz digital audio, so arrives at each point in the chain with exactly the same performance, even over very long distances. No other manufacturer provides such integrated audio and control networking capabilities over a single cable and network, at distances up to 300 metres/1,000 feet.



Easy to Operate

From untrained operators and staff to fully-trained engineers, you can leave a Soundweb system with whatever degree of local control you like, whether it's no control whatsoever, or simple volume and switches for waiters and bar staff, or more sophisticated programmable control using the 9010 'Jellyfish' controller. This latter option provides customisable menu screens and a rotary encoder that can control virtually any system parameter that you choose to assign to it.

The most control obviously comes from leaving a PC on-line to the system with the original design file running. If you leave this PC for local control, ten levels of password protection offer your design the security you'll be happy with.



Easy to Integrate

Soundweb also has comprehensive RS-232 serial interfacing, so that you can control the audio from external multimedia systems such as AMX or Crestron panels. Creating the control scripts for these systems is made easy within Soundweb Designer, while a complete serial interface programmers development kit is readily available and supplied with every unit on CD.



Soundweb doesn't stop at audio. Integrate audio with video using the SW9016 Video/Audio Matrix Switcher to control the simultaneous routing of video and audio sources to several zones, all under Soundweb control, or through AMX/Crestron multimedia systems.

A New Filter Design for Outstanding Performance

The new Version 2.0 firmware includes new filter designs in the shape of the WHISEWORKS – NTM* topology. This new design, developed by Neville Thiele and patented by Australia's Precision Audio, provides the fastest roll-off slopes outside of the pass band in modern IIR filter designs, while maintaining zero phase difference between adjacent bands throughout the crossover region, preventing beam-tilting. Listening tests have shown a marked and noticeable enhancement in performance over traditional Linkwitz-Riley 48dB filters. The new filters are kinder on the ear, and like the L-R design also maintain a flat frequency response throughout the crossover region.

**So if you want the best for your clients, and a future-proof installation, there can only be one choice —
Soundweb by BSS Audio.**

*The words "WHISEworks", "Neville Thiele Method" and NTM logotype are trademarks of Precision Audio Pty. Ltd. Manufactured under licence from Precision Audio Pty. Ltd.



The Soundweb Network



The Soundweb network is based on a proprietary custom FPGA, which allows the transmission of 8 channels of 24 bit, 48 kHz audio in each direction, and also provides around 3 Mbit/s of bandwidth for control packets - these are used to send parameter changes, meter data, and various other control items.

Soundweb was one of the first systems to offer both audio and control networking on a single cable, and remains one of the easiest to install and use. Designed to incur only a very low latency, Soundweb systems are ideal for use in delay-sensitive applications such as Theatre Sound and other live events, including use on monitor systems.

The network uses standard category 5 cable, and connection is made via readily available RJ-45 connectors. No IT or network management knowledge is required, nor is any external networking hardware.



SIMPLE SYSTEMS

The simplest Soundweb network is formed by connecting one RJ-45 cable between two Soundweb 9088iis's, which can be up to 300 metres/1,000 feet long. This enables 8 channels of audio plus control to travel between the two units. The existence of the control path means, for example, that a potentiometer connected to the control inputs on one unit can be used to control the output gain of a mixer in the other unit, and also allows a PC plugged into either one of the units to reload programs and adjust parameters on both devices.

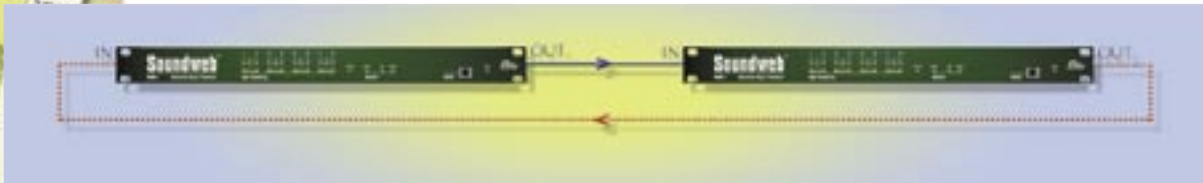
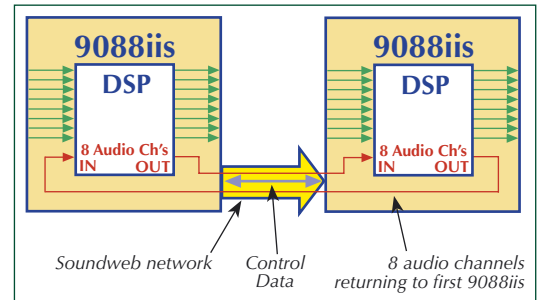

The dotted line shows the 'virtual' return path of the audio; no physical connection is made between these other network ports.

LARGER SYSTEMS

For larger systems, daisy-chain a number of 9088iis's. In this case the network 'Out' jack of the first device is connected to the network 'In' jack of the second, then the 'Out' jack of this unit is connected to the 'In' jack of the third, and so on.

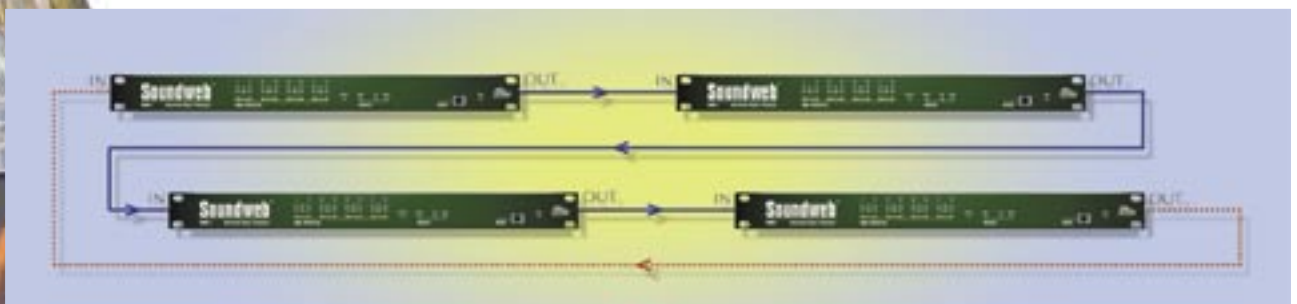
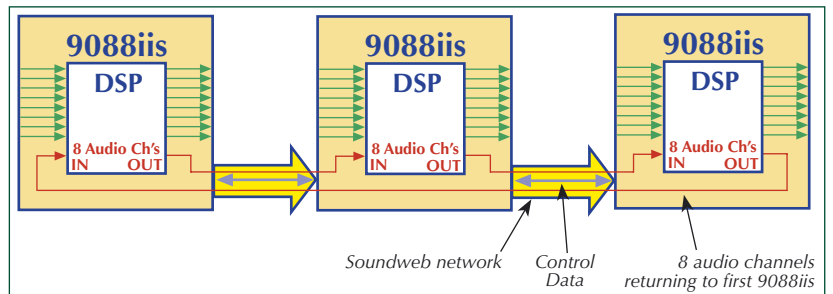

The 9088iis's form an audio ring in which 8 channels travel from the first unit to the last and then back to the first. At each device a channel can either be passed on from the previous unit in the ring or, replaced by an audio signal from one of the inputs or processing objects.

COMPLEX SYSTEMS

To produce more complex networks, the Soundweb 9000iis hub is used. Each hub has six network jacks; each generating a full 8 channels of audio in each direction. It is possible to hook a chain of 9088s to each hub jack, so that the hub forms the interlock point between the audio rings. Multiple hubs can be connected together, and multiple connections can be made between these hubs to increase the number of channels available. Working on this principle a 'web' of processing devices can be built up; so naming the product.

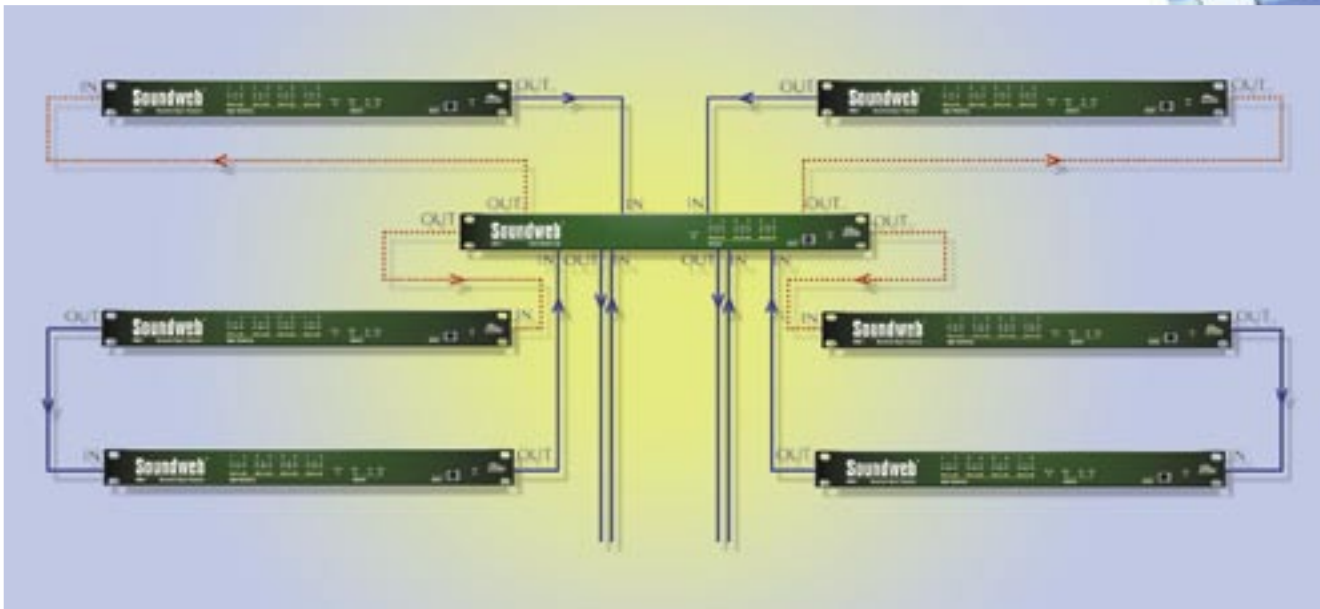

If a

Soundweb unit should lose contact with the rest of the network (perhaps because of a cable fault or power failure downline in another unit), it will continue operating according to its current audio settings. If power is removed and re-applied, it will recover the settings which were in force at the time that the power failed. The reason that this is possible is because of Soundweb's distributed processing.

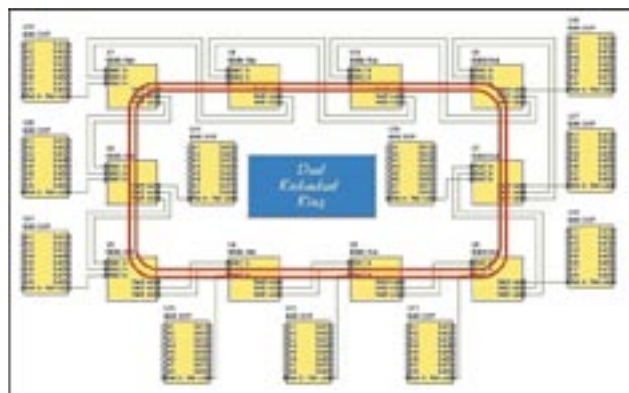

A dual redundant ring fault tolerant system has been developed for critical voice-evacuation situations using the 9000iis network hubs. The system will detect a break in a network cable, and choose the routing of the audio signals accordingly.

first.

Soundweb™



Flexibility is the key

CLUBS AND RESTAURANTS



Caddy Shack, USA

The SW 9016 Audio/Video Matrix Switcher was recently installed at the new Murray Bros. Caddy Shack theme restaurant in Myrtle Beach. Taking its name from the hit 1980 Warner Bros. film co-written by Brian-Doyle Murray and starring his famous brother, Bill, as loony greens keeper Carl Spackler, the two Murrays and their four other brothers are all partners in the venture.

Orlando-based production company Paradise Sound and Light, won the bid for the audio and video systems based on a design by Dave Becker, A/V Systems Integration Division.

"This is probably the sixth or seventh installation I've done with Soundweb devices and they always amaze me," notes Becker. "You can get so much performance out of such a small package. The heart of Caddy Shack's entire audio and video system is pretty much contained within four single-rack-space units."

Becker describes how the 9016 is being implemented: "All of the restaurant's video sources are patched into the BSS matrix switcher, including eight satellite receivers that are combined in one dish system as well as DVDs, VCRs and other sources. Aside from routing signals out to numerous televisions throughout the facility, the 9016 feeds out to a video splitter, the four outputs of which are tied into an NTSC quad generator allowing four games to be shown at once on each of the restaurant's 150-inch TVs in the Bunker Bar. It worked out really well and looks very nice."

Along with the 9016, the Murray Bros. Caddy Shack system includes several other Soundweb products, including a 9088ii DSP unit, one 9008 output expander and one 9010 programmable "Jellyfish" remote controller.

Chicago Rock Café, UK

Luminar Leisure have carried out a major £1m conversion of their Chicago Rock Café in Northampton, UK, providing the company with a flagship venue and increasing the capacity to 1500. With the relocation of the stage to its own mezzanine level, the venue is centred around live music. The large venue (with a massive 18 metres floor-to-ceiling height) is divided into three areas — the main room, the restaurant and Cuba Bar, situated inside the main entrance — and this is configured as a 16-zone system.



The primary task facing installer Lynx Lighting was the ability to change the venue's soundscape — with automatic

adjustment of the room's EQ settings in accordance with the different modes of music. This they did with the aid of four BSS 9088 Soundwebs and a 9010 Jellyfish remote. Via Soundweb, each area can select local sources, such as satellite — or multiplay CD in the Cuba Bar — while still receiving announcements from the main DJ booth.

Four BSS 9012 wall-mount panels provide the local user interface — featuring a five-way switch and rotary fader. However, in the live mixing area on the balcony, the house engineer has access to the Jellyfish and this allows him to override the system at any time.

The idea is to use the different processing blocks from each Soundweb to route around the whole network. The DSP is used for matrix routing and storing gain settings and limiting — delays in particular are used heavily depending on the different loudspeaker set-ups. As soon as a band takes the stage, emphasis switches to the front of the room and the delay settings will change. The engineer will type a preset and reconfigure in the Jellyfish.

System Designer Jerry Denning states "Soundweb proves itself every time. This is because engineers' requirements change once you are on site. And so rather than have to add another analogue processor at the 11th. hour, it's simply a case of a few minutes' re-programming to extend his virtual dynamics."

Paging and simple control



Furzeffield Centre, UK

Major leisure and fitness centre — the Furzeffield Centre in Potters Bar, UK — had been experiencing communications difficulties since undergoing a major refurbishment programme a few years ago. Local company Promedia Systems diagnosed that an audio cabling redesign and deployment of a BSS Soundweb system, with a touchscreen-driven front end, would provide the best solution to their public address requirements, and facilitate paging messages to the correct zones.

The result is a system that the front-of-house reception desk staff have been able to embrace with the minimum of training.

They rationalised all the cables and replaced all the amplifiers that weren't working – as well as specifying two 9088ii Soundwebs and a touchscreen to handle the front end. Via Soundweb, Promedia even applied tone generation to two duckers, linked together, to create the classic paging 'bing bong' sound.

Promedia also adopted the feature that allows Soundweb to load automatically at computer switch-on, whereupon it goes online and full screen (in this instance to a 15.1" TFT touchscreen resistive panel). The control surface is broken down into the 12 different zones around the venue (14 including induction loops). The zones can be highlighted and the respective mic activated at the press of the button.

This is a highly intuitive system, even with a lot of background music implemented, – from a general CD player as well as a dedicated gym CD player and a tuner – staff can easily select each music source in any of the zones from the touch panel. Soundweb also stores parametric EQ settings for the zones.

Ford Field, USA

Ford Field, the new \$500M home turf of the NFL's Detroit Lions, benefits from BSS Audio processing thanks to local contractor Sound Media who installed the entire audio system based on a general specification provided by WJHW of Dallas, Texas.

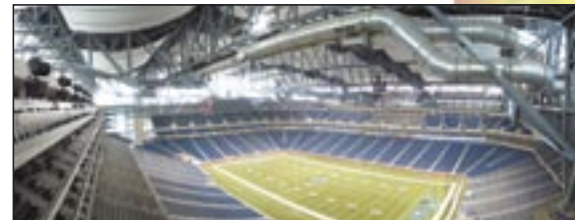

A Soundweb system comprised of five 9088ii DSP units and a 9000ii network hub is called upon to provide signal processing and routing for Ford Field's extensive back-of-house areas, including concourses, suites, concessions areas, restrooms, press facilities, interview rooms, locker rooms and other locations. Most of the 1.85M square foot facility's BOH spaces rely on JBL Control 25 loudspeakers for uniform audio coverage throughout.



Steve Robinson, president of Sound Media, elected to install BSS components right from the start. "I use BSS primarily for one reason: because it works. I put Soundweb into the Greektown Casino here in Detroit a while back and it runs great. No problems. No reliability issues. Just solid, dependable performance."

Robinson further cited "ease of programming with Soundweb Designer" and "helpful tech support" as other key reasons for choosing BSS gear.

Soundweb Designer running on a desktop PC provides control over the BOH system at Ford Field, while control over the other BSS devices in the bowl is via Soundbench software on a laptop.

Soundweb™



HOUSES OF WORSHIP



Distributing the Word

New Birth Missionary Church, USA

The New Birth Missionary Baptist Church in the Atlanta suburb of Livonia, GA is a very good example of how technology is becoming increasingly important and increasingly integral to the design and building of church and multimedia facilities, and particularly how sound has become very critical to the entire media design of the building.

Crucial to Custom Sound Designs' ability to meet all of the church's media needs was the choice of the Soundweb system controller and processing system. The ultimate goal was phenomenal sound to every seat in the house, and the sound sources range from a single voice in the pulpit to a six-hundred-voice choir with fifteen musicians and ten more solo singers. The Soundweb enabled the designers to connect the dots between the huge number of sound sources and the ultimate goal of perfect sound for everyone.

The system includes 20 SOUNDWEB DSP modules, a pair of 9000ii Hubs and five 9010 remotes. The control system also addresses audio system elements in a second building.

"Any of the church's technical personnel can use it easily to essentially send any signal, anywhere, anytime they want, as the circumstances change. Once it's in, there's not a whole lot that has to be done."

"That kind of adaptability and flexibility is not only nice to have, but absolutely necessary these days, because situations can change quite radically very quickly."

Doug Hood, General Manager of Custom Sound Designs

Salisbury Cathedral, UK

BSS Soundwebs are at the heart of an installation at Salisbury Cathedral, designed to make audio preset distribution a simple task for members of the vestry. The brief handed out by audio designer John Del Nero to BSS Audio for the routing of sound around Salisbury Cathedral's digital highway was to make the system conform to the traditional style of presentation, in an operator-friendly fashion. This was achieved using nine Soundweb 9088s, a 9000 hub and a 9010 'Jellyfish' remote. Vergers can select the type of service required, whereupon the system will reconfigure and the desired touch screen control panel will present itself.

The greatest challenge for BSS was in setting the correct delays. "Traditionally if a speech was being delivered from the East end of the cathedral, you would delay from East to West – and vice versa. But the problem comes when people start speaking in the middle of the nave. We solved this by putting delays on the inputs." Rather than the traditional technique of mixing mic signals together and delaying each speaker send, John Del Nero's design uses five discrete time delays for each cabinet, utilised dependant on where the signal originates.

BSS also use a Fujitsu Stylistic PC touch screen working on a radio-wave LAN, which can be operated from any part of the Cathedral. The main page has a plan of the cathedral and dropped onto that are little LEDs to show the status of each microphone - using a similar graphical representation of the loudspeaker zones, with presets which activate the system components required for a given service.



Soo Young Roo Church, Korea

major new-build house of worship in Pusan, Korea's second largest city, has its audio communication through the various auditoria networked via a number of 9088ii Soundweb digital devices.

main 5,000-seat sanctuary at the Soo Young Ro Presbyterian Church is joined by an 1800-seat and several 900-seat satellite chapels, all within a single complex.

design is based around 18 Soundwebs and other BSS processing hardware, and installed by Daiyoung, distributor. These take a live mix from the choir and floating mics used by the clergy, via a Soundcraft Series FIVE console and also routes the audio from the recording studio, based on the site. There is also an editing room, and the audio tracks are also processed through Soundweb. Services in the main sanctuary be televised and relayed into the smaller chapels.



Audio Visual



Hodler-Saal, Germany

Installers Horn Audio-Video-Systeme won the contract to install a BSS Soundweb system — comprising eight 9088MM and two 9010 Jellyfish — bringing Hanover's historic Hodler-Saal town hall into the 21st century.

The requirement was for a system that would enable council discussions to be heard with clarity and monitored with ease. Essentially the new discussion system needed to be tactfully integrated into this historical room in a way that would not disturb the optics of

the hall. The system needed to be practically invisible, user friendly and enable multiple and individual control for each member present.

Consultant Wolfgang Kintscher chose Soundweb on the strength of its flexibility. The Soundweb system controls over 60 microphones available to the members, each of whom can activate his or her microphone manually. Automatic mixers then control the levels, whilst the overall volume can be controlled by the chairman — allowing him the ability to direct the forum efficiently. The system is also designed to automatically prevent more than four mics being active at

Gonzales Convention Center, USA

Soundweb Processors were selected to outfit the Gonzales Convention Center expansion in San Antonio, Texas. Over seventy 9088/9000 DSP processors and an additional eighty 9010 'Jellyfish' remote controls are in use. The Soundweb Network is used to transport audio signals originating from the main A/V room, such as background music, paging and audio for video, to the various rooms throughout the convention center.

The recent Gonzales expansion consists of three exhibit halls, which can be combined or divided, one large banquet/meeting/performance hall, pre-function area and 26 meeting rooms. Additional rooms have also been constructed.

Conference room mixing and combining is done utilising the Gain-sharing automixer algorithm and matrix mixing between rooms. Soundweb processing was chosen for the versatility the network provides as well as the plethora of control options available for each room. In addition, the Soundweb system is expandable, making the next two phases of expansion just as easy.

Richard Bertrand of ASC says of the Soundweb system, "It's amazing! With simple CAT 5 networking, we are able to eliminate miles of analogue multi pair wire. Control is seamless. When you operate a remote control to bring up the background music, you forget you are operating a device over a half mile away! The digital delivery of audio via the Soundweb network saved the client hundred of thousands of dollars and resulted in vastly improved quality. It was the only solution available for this venue to work."

The design features an elaborate three stage paging override in the design to allow for local, wide area or emergency override paging. Design and installation was supervised by ASC Company of Dallas, Texas.



**BOARDROOMS &
CONFERENCE
CENTRES**

System Design and Soundweb Designer

Systems are designed around three basic hardware devices: The 9088iis DSP unit with 8 analogue inputs and outputs, the 9008iis output expander with 8 analogue outputs, and the 9000iis network hub. Each of these devices contains its own DSP power that can be programmed the way you want.



Another device, the 3088 Soundweb Lite, has all the functionality of a 9088iis, but with no networking capability. For simple 8x8 systems, the 3088 provides an elegant, lower-cost solution.

The system design software, Soundweb Designer, runs on a PC under Windows™ 95, 98, NT, 2000, or XP.

Soundweb Designer

The main screen in Soundweb Designer is where the system layout begins. The Soundweb devices are simply added to this screen to produce the necessary input/output configuration, and hubs added where network demands mean more signals are fed around.

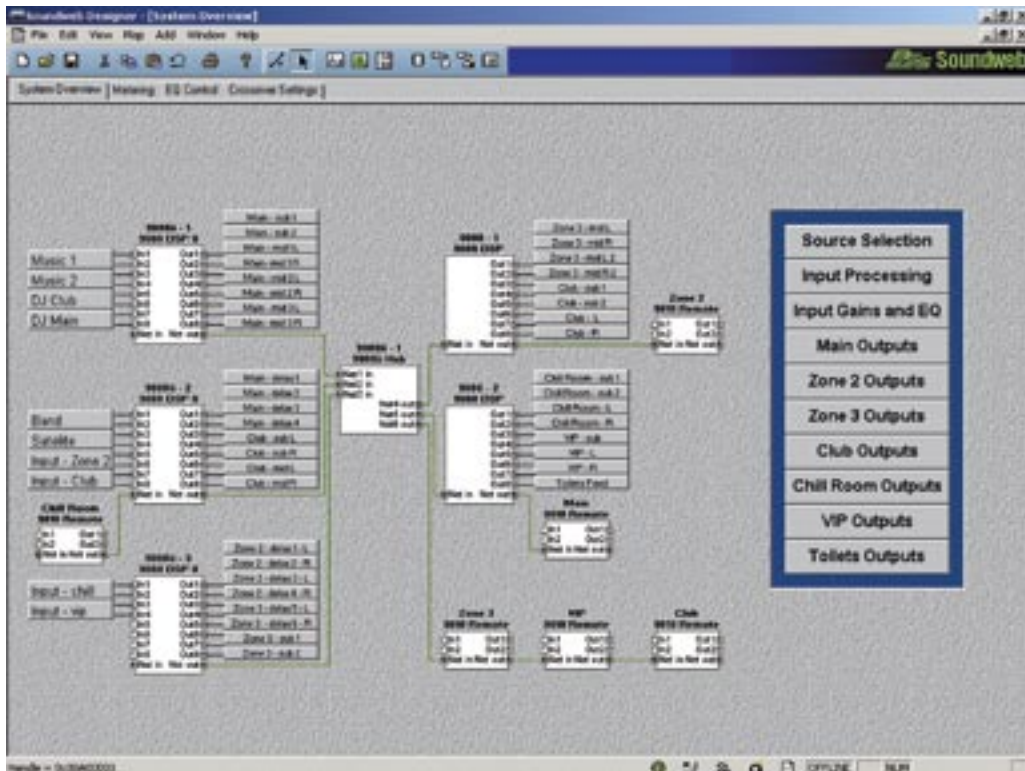

This overall system design can incorporate images of the installation, text boxes and equipment icons, so that a total representation of the complex is shown. Once your design is complete, you can export this as a Windows™ Metafile for inclusion in other documentation or CAD programs.

These 'Map' windows can contain system designs, or used to create custom control panels (see page 12). Custom control panels could be, for example, a set of meters for instant monitoring, or a set of EQ controls for each area. Navigating between multiple windows is because you can place linking buttons on each window, or use tabs on the top of each window.

Your finished design can then be exported as a 'shopping list' using the View Kit List function. This allows you to print a complete list of devices and network connections for inclusion in bid specifications.

Designing your processing layout

To design your signal processing path, double-click on one of the DSP devices. Here you're presented with the input, output and network nodes, and a clear screen for you to design the processing you need. The layout of the processing is completely flexible. Processing objects are represented on the PC screen by boxes with connection points for their inputs and outputs; these are simply hooked up using a CAD-like interface, to produce any layout that may be desired. To add an object, simply drag its item from the palette list on the left.

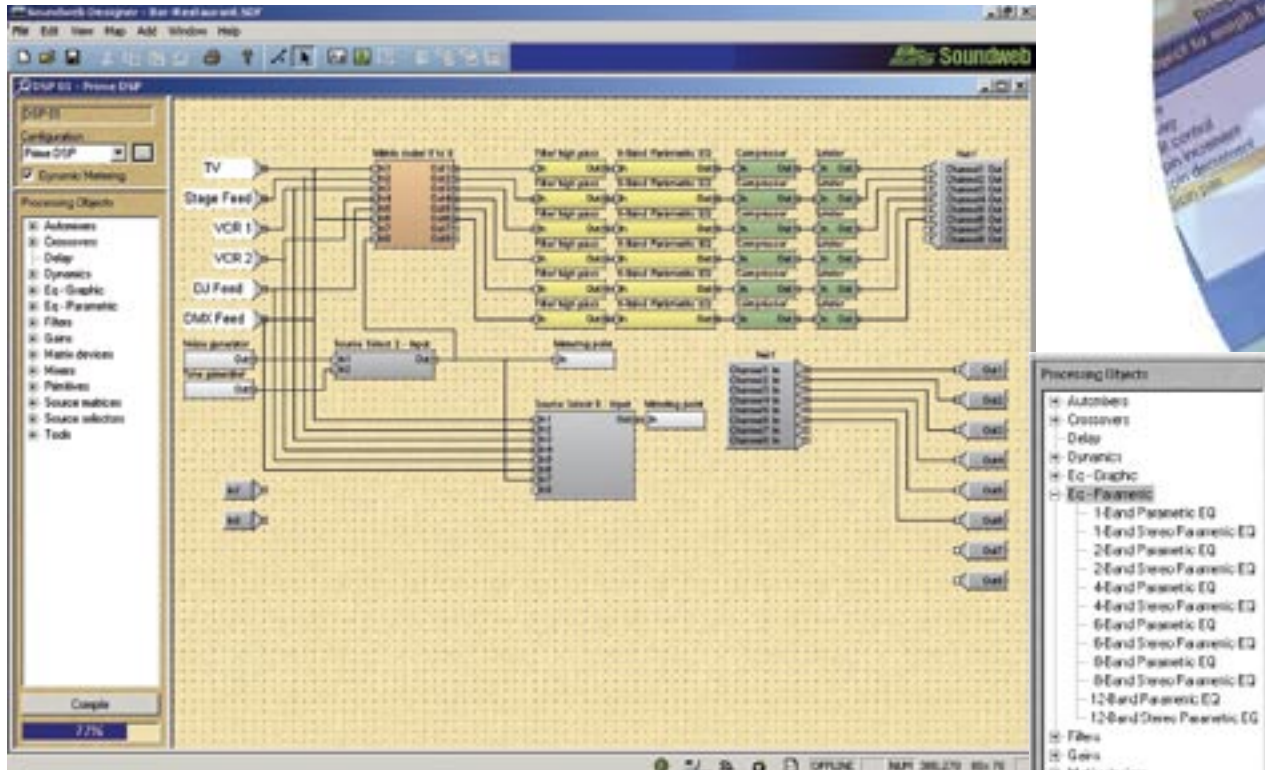

Simply interconnect the processing objects with the 'wire' mode, complete the design, and compile the DSP. You're ready to upload the design to a Soundweb device.

DSP Power – how much can you have?

The amount of DSP power in a Soundweb device is 200MIPS (million instructions per second). The amount of power needed for processing the audio depends on the design complexity, but in real terms a single Soundweb 9088iis could for example, implement 14 channels of 12-band parametric EQ; or 8 channels with a compressor and gate in each; or a stereo 4-way crossover with limiters, delays and 12 bands of parametric EQ on each output and a stereo compressor on the input.

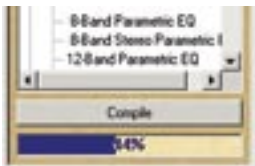

The configuration window includes a DSP resource meter that shows how much DSP processing capacity you are using in that device. You will normally find that you have more than enough capacity for quite complex systems. However, in a networked system, it is possible to utilize spare DSP in another device by sending a signal across the network and back after processing.

Once you have designed your DSP layout, it is saved as a CONFIGURATION. By starting a new configuration you can have a completely different set of DSP objects and routing as another design, and save that.

Each Soundweb device can store about 60 completely different DSP configurations in memory, which can be recalled simply either within the configuration window or as part of a system-wide PRESET (see page 12). This allows you to completely change a system's setup for a different event at the touch of a single button.

Control panels

Soundweb Designer provides default control panels to allow the adjustment of each audio processing object, which are activated by double-clicking on the object when in the processing design window.

In addition to using these, you can build your own 'custom' control panels. The software allows a great deal of customisation of the panel layouts, including the use of colour or images as backgrounds, and control over the shape, size, colour and edge styles of particular control items such as faders or buttons. Some types of object can be 'morphed' into other types, such as a fader into a rotary pot or a pair of 'up/down' spin buttons.



Control Options & Control Ports

Using the control inputs and logic outputs, it is possible to provide a custom hardware control panel for the facility. This can be built from readily available off the shelf components, and can be made to whatever cosmetic styling is required; an engraved brass plate for a hotel reception would be an example. We offer standard simple devices, such as the 9012 Wall Panel that combines a 5-way switch (source selector or preset switcher, for example) and a rotary fader (for level).



The logic outputs can be used to provide an indicator for any binary output function such as a gate open light, or to provide a tally for a switch.

Cost-Effective Control of External Devices

Every Soundweb DSP unit has eight logic control output ports. That includes the 9088iis networked signal processor, the 9008iis networked output expander, the 900iis active network hub and the newer, lower cost non-networked 3088 Soundweb Lite.

Using low-cost, third party logic converters, these output control ports can provide the following functions:

- Infrared Control
- High Current relay
- Latching Relay
- Momentary Relay
- MIDI Control
- Serial Control

The bottom line? You can successfully convert to the superior Soundweb DSP and control platform when all of the following conditions are present:

- An advanced, "control any device" automation system is specified.
- Lower priced, lower performing audio DSP has been specified, or is being considered, to replace Soundweb due to "value engineering".
- The list of external control commands required fits the total number of output control ports if Soundweb were to be specified.
- Complex functionality is not required, i.e. sophisticated feedback from external devices, video streaming in a window on a touch screen, etc.

Depending on which Soundweb control device is chosen (and what is being replaced), these conversions should result in significant savings compared to using the most commonly specified control/automation systems.

Presets – full system changes or just parameters

Soundweb Designer allows you to specify 'presets'; these are complete records of the state of your system that can be stored or recalled as necessary. 'Parameter presets' are a variation on this that allow you to store and recall the state of a particular group of parameters, without affecting the whole system.

Most commonly, presets are used to recall different sets of parameter adjustments. However, they can do more than this. If a preset being recalled requires a different dsp 'configuration' from the currently active layout within a Soundweb device, the unit will mute its outputs and reload the DSP with the appropriate program before continuing. Each Soundweb unit can store up to 60 totally different DSP layouts or configurations.



Password Protection for security

Soundweb Designer allows you to specify multi-level password protection for your system. You can define different users, assign security levels to each user, and then dictate that certain features of the system require a particular security level in order to allow them to be operated. You can also specify that a particular user should be forced into a particular control panel at start-up, thus ensuring that personnel get just the control screens that you have in mind for them.



Macros

Macros allow you to group together frequently used collections of processing objects, complete with their usual settings. Once defined, a macro looks to the user exactly like any other processing object.

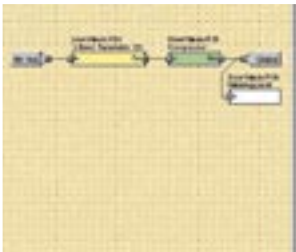

Macros can be used as a way of protecting a consultant's intellectual property. Details of the macro definition are not available to the end user, who only sees the form of the macro, i.e. its inputs and outputs, and the parameters that are available for adjustment.

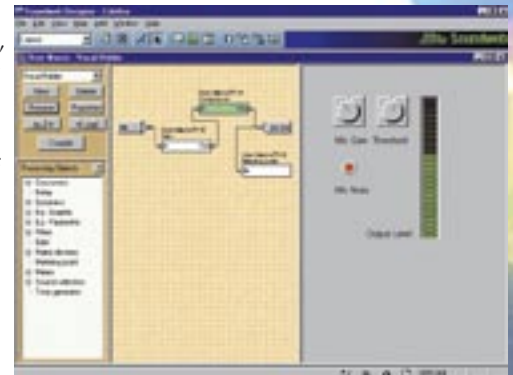

Serial Control

The serial port connector on the back of a Soundweb device can be used to interface to an external control system. Currently devices supported include AMX, Crestron, Dataton and Avenger.

Requirements differ for interfacing to these systems. For an AMX system, the user exports a header file suitable for inclusion with the AMX program (BSS provide a suitable library file to support the AXCESS compiler). With Crestron systems, the user edits the Crestron control data to map the control icons to the Soundweb elements. Similarly, other systems can use the RS-232 control strings to access Soundweb parameters.



Watching for problems

System performance can be monitored using Soundweb's Event Logging system. Events that can be allocated to be recorded include failures, warnings and information notices. The time of the event occurrence, the device to which the event applies and the design file originally loaded are all displayed. An auto backup facility ensures that the logs generated by larger systems remain manageable.



SW9088iis Networked Signal Processor

The Soundweb 9088iis DSP unit is the heart of the Soundweb system. As a standalone single rack space device it has all the facilities required for a sound system processor - 8 inputs, 8 outputs, a DSP engine, networking for connection and signal distribution to other soundweb units, Analogue GPI control interfacing, and RS232 ports for external control by PC or AMX/Crestron type systems. Plug in an audio source, an amplifier, and speakers and you are away.

- ❑ 8 Analogue Mic/Line Inputs and 8 Analogue Outputs.
- ❑ Optional AES/EBU digital input/output (2 x stereo) cards with external word clock input.
- ❑ 200MIPS of DSP resource.
- ❑ Integral multi-voltage PSU, (85V - 270V AC).
- ❑ Analogue control ports for GPI hardware interfacing; eg faders, switches & LEDs.
- ❑ Front and rear access RS232 ports for PC control.
- ❑ Integral memory holds up to 60 DSP system designs, depending on complexity.
- ❑ Optional cable lacing bar.



All the facilities are included in a 9088iis, there is no additional Soundweb system hardware required to begin building physical systems. The only option decision to make is a choice of line input, mic/line input cards or AES/EBU Digital input/output cards. Each analogue card handles four inputs and each input can be switched individually, together with phantom power and phase reversal. Each digital card accepts 2 stereo inputs at sample rates from 32kHz to 96kHz, and has two stereo digital outputs at selectable rates of 44.1, 48, 88.2, and 96kHz. When digital inputs are used, the analogue outputs remain in use as a mirror version of the digital output.



I/O connections are made via 'Phoenix' style two-part screw terminals; the female connectors are shipped with the Soundweb unit, so installation can be made with no soldering and no extra connectors to buy.

Each Soundweb 9088iis can typically hold up to 60 completely different system designs in its own memory. Programming the unit is accomplished via the Soundweb Designer software, available free of charge from BSS Audio (www.bss.co.uk).

Front and rear RS232 ports are provided for programming, firmware upgrade access and for connection to control systems such as AMX, Crestron or similar.

For safety-critical systems, the Soundweb 9088iis has an opto-isolated output which functions as a watchdog: the opto-isolator conducts when power is applied to the unit and the software is functioning correctly; it is cut off if there has been a power failure or other fault. This function can be used to trigger alarm systems or to construct redundant systems.

Soundweb lite 3088 Signal Processor

For simple standalone 8x8 DSP processing, the Soundweb Lite 3088 draws on the phenomenal success of the larger networked Soundweb 9088iis and associated products, but provides a less-expensive alternative for situations where the design requires a maximum of 8 inputs and 8 outputs. There are no network facilities on the 3088, hence the lower price.

This device will fulfil many applications such as small houses of worship, theme bars, boardrooms and clubs.



- ❑ 8 Analogue Mic/Line Inputs and 8 Analogue Outputs.
- ❑ Optional AES/EBU digital input/output (2 x stereo) cards with external word clock input.
- ❑ 200MIPS of DSP resource.
- ❑ Integral multi-voltage PSU, (85V - 270V AC).
- ❑ Analogue control ports for GPI hardware interfacing; eg faders, switches & LEDs.
- ❑ Front and rear access RS232 ports for PC control.
- ❑ Integral memory holds up to 60 DSP system designs.
- ❑ Optional cable lacing bar.

The 3088 has all the capabilities of the networked version — totally free-design DSP layout, a large palette of processing objects, custom control panels etc, and runs under the common Soundweb Designer platform. This means that Consultants and Contractors who are familiar with Soundweb already will be able to incorporate designs using the 3088 immediately.

Control options for the 3088 are similar to the 9088iis, with PC control (custom control panels), simple control from the 9012 and 9015 wall panels and control ports, or serial control from AMX, Crestron and other serial-based control systems. However, as there is no network, the 9010 controller cannot be used with the 3088.

All standard input configuration options are available for the 3088, including mic, line and AES/EBU digital I/O. The 3088 will also integrate with the 9016 Video/Audio and 9026 Audio switchers.

Soundweb 9008iis Output Expander/Processor

The 9008iis hardware device is an expansion unit for Soundweb systems where more outputs are needed, but input sources are already covered using 9088iis. The 9008iis is almost identical to the 9088iis, and delivers the same DSP and control capabilities, but lacks any input circuitry. By dispensing with the input cards, and associated sockets the 9008iis is cost effective in situations where extra inputs are unnecessary.

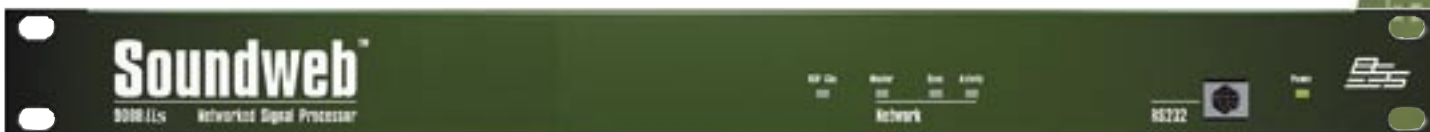

- ❑ 8 Analogue Outputs only, no input capability except via network.
- ❑ 200MIPS of DSP resource.
- ❑ Integral multi-voltage PSU, (85V - 270V AC).
- ❑ Analogue control ports for GPI hardware interfacing; eg faders, switches & LEDs.
- ❑ Front and rear access RS232 ports for PC control.
- ❑ Integral memory holds up to 60 DSP system designs.
- ❑ Optional cable lacing bar.

The unit is envisaged to be especially useful providing additional outputs for larger systems where each additional 9008iis can route and process up to 8 channels of audio to its balanced outputs. Also with its built in networking capabilities the 9008iis can communicate with all the other Soundweb devices on the network.

SW9000iis Network Hub

The Soundweb 9000iis Network hub is used to expand the routing capabilities of the Soundweb system. It has all the processing facilities of the 9088iis DSP unit; 200MIPS of DSP horsepower, analogue GPI control interfacing, and RS232 ports for external control by PC or AMX/Crestron type systems; but has 6 network ports instead of analogue inputs and outputs.



Like the 9088iis, each 9000iis can hold up to 60 completely different system designs in its own memory. The DSP in a 9000iis hub is most often used for matrixing, mixing, and routing the signals from 9088iis devices, which are then free for signal processing.

The 9000iis Hub occupies just a single rack space (1U) and includes its own power supply. Programming the unit is also accomplished via the Soundweb Designer software.

The 9000iis can be used to extend the matrixing and signal routing capabilities of a Soundweb System Network, and large systems can be constructed using one or more 9000iis hubs to interface with 9088iis devices.

- ❑ 6 Network ports.
- ❑ 200MIPS of DSP resource with all the DSP processing objects of the 9088iis.
- ❑ Integral PSU.
- ❑ Control ports for analogue GPI hardware interfacing.
- ❑ Front and rear access RS232 ports for PC control.
- ❑ Integral memory holds up to 60 DSP system designs.

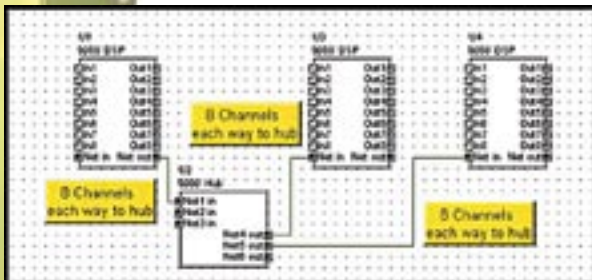

As an example, a single 9000iis hub linked to three 9088iis devices can produce a fully matrixed 24 x 24 system.

Hubs can also be connected to each other to form large signal busses. Again, as an example, a 24-way bus could be designed quite easily.

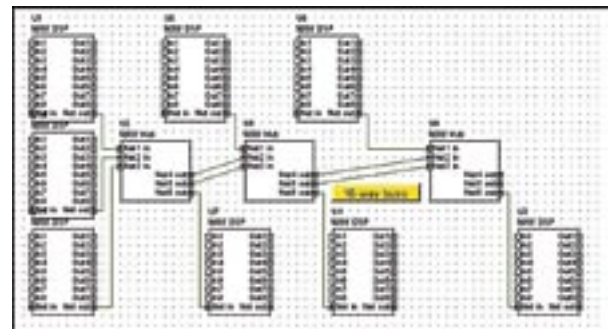

For safety-critical systems, the Soundweb 9000iis has an opto-isolated output which functions as a watchdog: the opto-isolator conducts when power is applied to the unit and the software is functioning correctly; it is cut off if there has been a power failure or another fault.

This function can be used to trigger alarm systems or to construct redundant systems.

Dual Redundant Ring System

Using Soundweb 9000iis hubs, it is possible to create a dual-redundant ring, where two network cables carry audio and control around a ring in both directions, so that if one cable is accidentally damaged, the other intelligently routes the signals to continue full operation. (see page 5).

SW9016 Video/Audio Switcher

SW9026 Audio Switcher

The SW9016 and SW9026 Matrix Switchers allow video and audio sources to be routed by Soundweb Designer presets or simple remote control.

The SW9016 Video/Audio Matrix Switcher features 8 video source inputs (NTSC or PAL) on BNC connections, along with 16 balanced audio inputs which allow easy input expansion for Soundweb audio inputs. Four video output zones are fed from BNC connectors with 8 balanced audio outputs.



The SW9026 Audio Matrix Switcher features 16 balanced audio inputs, and 8 balanced outputs which can then feed a Soundweb 9088iis for processing and further zone distribution.



Integrating Soundweb Audio Processing and Networking with these switchers provides a unique and totally integrated multimedia processing system for Theme Bars, Restaurants, Clubs, Home Theatre Systems, Videoconferencing, Corporate Boardrooms, Classrooms and other environments where there may be several areas, each requiring its own video/audio feed possibilities. In these systems, the theme is very much 'video follows audio' in that the video feeds are switched when the audio sources are re-routed according to event need, with the ability to break audio and video sources. This means, for example, that a zone could have Sport video with radio audio playing.

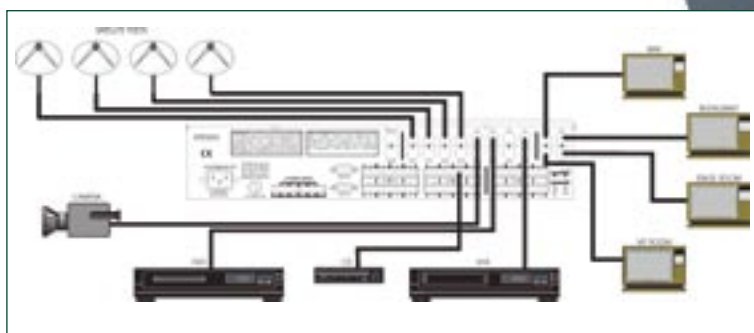

- SW9016 - 8 Video input sources and 16 audio inputs matrixable to 4 video outputs and 8 balanced audio outputs, either audio follows-video or independently, with audio output level controls.
- SW9026 - 16 audio inputs matrixable to 8 balanced audio outputs, with audio output level controls.
- Controlled via Soundweb Designer or 9010/9012 controller presets, or a standalone PC application, MatrixMate.
- Simple control via simple switches.
- Two units may be cascaded to increase capacity.

There are many instances where only a number of signals from multiple sources are required simultaneously, and the SW9026 permits low-cost input expansion for Soundweb systems, as well as offering a standalone solution for source selection and matrixing.

In addition to seamless integration within Soundweb systems, the SW9016 and SW9026 switchers are equally suited to stand alone operation. When used in this way they can be used as simple routing switches or alternatively loaded with up to eight pre-sets that allow any combination of audio/video routing and audio level to be instantly recalled in up to four independent zones. If no pre-sets are loaded, the units automatically default to a simple four zone source selector with 'audio follows video' routing, audio level control being independent for each zone.

Control can be remote via RS232 using simple string commands, or local from a contact closure port, for example using up to four 9012 panels.

BSS Audio supplies a standalone PC program, MatrixMate, that can be used to both set-up and control the devices when they are not part of a Soundweb system.

SW9010 'Jellyfish' Programmable Remote Controller

The Soundweb 9010 Remote control is the long awaited solution to the problem of providing a sophisticated system control interface that requires no technical knowledge to operate.

The 9010 extends the already outstanding flexibility of the Soundweb system by providing multi-purpose programmable remote control. The 9010 has a rotary encoder and 6 push buttons which are labelled by a graphic LCD display.

The encoder and each button can be used to adjust almost any processing parameter within a Soundweb network: the user sets up the functions in the Soundweb Designer software. Multiple "control pages" can be constructed with navigation between them and password protection; a button can have a different function in each page.



- ❑ Backlit graphic liquid crystal display with programmable layout.
- ❑ One programmable continuous rotary encoder to adjust parameters.
- ❑ Six programmable pushbuttons.
- ❑ Internal electret capsule microphone with computer-controlled gain.
- ❑ External dynamic microphone input with computer-controlled gain.
- ❑ Two channel audio output.
- ❑ Available in green or beige finish.



Mechanical Installation

The 9010 Remote is designed to fit into a standard US 3-gang wallbox (available from BSS Audio) using the screws provided with the unit. We also offer a decorative bezel that fits around the 9010 when mounted in this box.

In addition to its control facilities, the 9010 provides an internal capsule microphone, an external microphone input, and two channels of audio output. With suitable external amplification and loudspeakers, these audio outputs can be used for local monitoring of network signals or local communications.

The 9010 connects into the Soundweb network using RJ-45 connectors and CAT 5 cable, just like any other Soundweb device. The 9010 is powered from a standard 24V DC power supply; BSS can provide a suitable supply capable of powering four 9010s. The optional 9011 adapter allows the power to be sent to a daisy chain of 9010's down the network cable.

Programming the 9010

To program the 9010, the 'Button Setup' function within Soundweb Designer opens a design window, which allows the user to decide the functions of each button and the encoder, whether it is to adjust parameters, trigger presets or change menu pages. The 9010 can control virtually any parameter of any Soundweb DSP device on the network.

To assign a button to a fader to control gain, for example, it is simply a matter of opening the fader control panel (in design mode) and dragging the fader onto the desired button. The button adds default text which may be changed with the text tool. When the button is pressed on the actual remote, the encoder will then control that fader.

Parameter controls, presets and parameter presets can all be placed onto buttons. Buttons can also be used to address new menu pages, by first creating a new page, then programming a button to access that page. These pages can be password protected for security. In this way, some functions can be left for general facility staff to operate, while other functions are secured for technician's use.

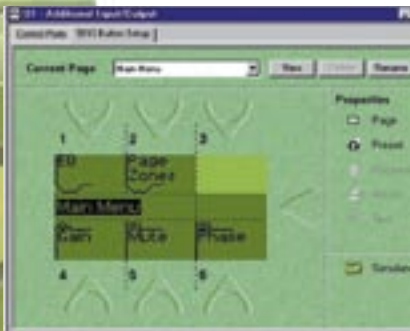

Programming can be totally checked off-line on the PC with the powerful 'simulate' mode.

SW9012 Wall Panel



The Soundweb 9012 Wall Panel is a simple hardware interface to the Soundweb Programmable DSP system. It provides a quick and easy way for designers to provide a rotary fader control and source select (or other multiway switch function) in a standard UK-sized light switch panel mounting.

- ❑ Rotary fader for Volume control etc.
- ❑ 5-way rotary switch for source select etc.
- ❑ Standard UK light-switch fitting mounting size, in green.
- ❑ Available in USA single gang switch fitting in beige.



Using Soundweb Designer to 'map' functions onto the Soundweb device control ports, these hardware controls can then be used to provide local control of, for example, volume, source select, or parameter presets.

Connection is via the Soundweb standard Phoenix/Combicon removable screw terminal connectors. Three terminals are used for common, switch output and fader output.

The switch has blank ident areas for marking the switch positions, either directly onto the white area or on self-adhesive labels. A set of 'standard' labels in four languages (English, French, German & Spanish) are supplied with the 9012 which should cover most locational requirements.

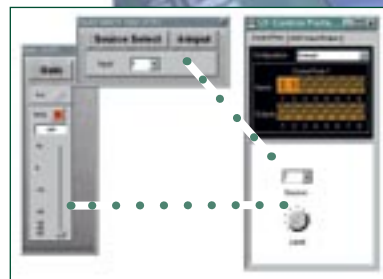

SW9015 Wall Panel

The SW9015 Wall Panel is similar to the SW9012, except that the rotary eight settings and the rotary level control is replaced by up and down buttons. (Green) or USA (Beige) single gang switch fittings.



switch allows
Available in UK

SW9014 Fibre Interface

Fibre for long distance

The 9014 Fibre Interface has been designed to extend the networking capabilities of the Soundweb system. Using the 9014 Fibre System, the distance between Soundweb devices can be increased to 2km/1.2 miles.

A pair of 9014 Fibre Interface units is used to replace a standard CAT 5 Soundweb network cable. Each fibre cable will transfer 8 channels of digital audio plus control data.

To utilise the fibre system, each end of the fibre link requires one 9014 device. Each device is equipped with an RJ-45 Soundweb network cable jack into which the network cable is connected, and two snap-in SC type fibre connectors. Two fibre cables are then required to connect between 9014 devices — this is to enable the bi-directional audio transfer.

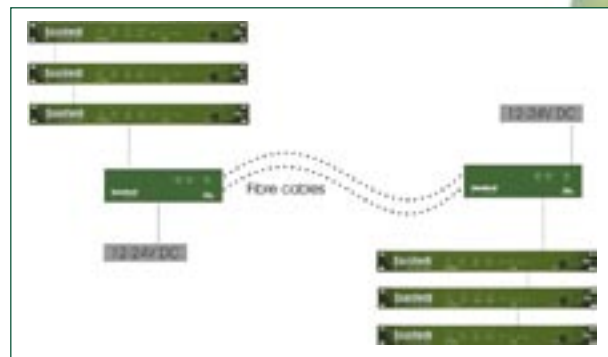

Each 9014 device requires a DC supply of 12V to 24V DC (BSS part Z-999-PSU). This PSU is capable of powering eight 9014 Fibre Interface modules. Power can be shared with the 9010 Remote Control, but not via the network cable.

Fibre for noise immunity

The added advantage of using a fibre system is that fibre itself is totally immune to outside noise and interference, so your audio signals remain pristine from end to end.

Multiple 9014 Interfaces

A mounting panel is available so that up to three 9014 devices may be installed in a single rack space.



Soundweb 9088iis, 9008iis, 3088 and 9000iis devices

DSP capability 200MIPS (Million Instructions Per Second)

Input Section (9088iis, 3088)

8 Analogue, electronically balanced, on Phoenix/Combicon removable screw connectors.
 Line Inputs: Nominal gain 0dB, electronically switchable to +12dB gain, input impedance 10kOhm
 Mic/Line Inputs: Nominal gain 0dB, electronically switchable up to +72dB, in +6dB steps, input impedance 3.5kOhm
 Maximum input level: +20dBu with 0dB input gain (+8dBu with 12dB gain)
 CMRR: >75dB at 1KHz
 Equivalent Input Noise: <-128dBu typ with 150 Ohms source (EIN)
 Phantom power: 48V nominal, selectable per input

Digital Input/Output option (9088iis, 3088)

2 x 2-channel inputs and 2 x 2-channel outputs per card, on Phoenix/Combicon removable screw connectors. Corresponding Analogue outputs remain live and in parallel with Digital outputs.
 Interface standard: AES/EBU
 Digital resolution: 24bit
 Supported input sampling rates: 32-96kHz
 Supported output sampling rates: 44.1, 48, 88.2, 96kHz (independent for each output)
 Output clock source: Internal, Inputs 1 & 2, External Word Clock or System Clock (48kHz)
 Input clock source: Independent or System Clock

Output Section (9088iis, 9008iis, 3088)

Maximum output level: +20 dBu
 Frequency response (±0.5 dB): 15 Hz to 20 kHz (±0.5dB)
 Total Harmonic Distortion (THD): <0.01% (20Hz to 0kHz, +10dBu output)
 Dynamic range: 105 dB typical (22 Hz to 22 kHz unweighted)
 108dB typical (A-weighted)
 Inter-channel crosstalk: <-75 dB

SW9016/9026 — Video/Audio Switcher and Audio Switcher

Video Inputs (SW9016): 8 Composite Video inputs (CBVS or SVideo) on BNC connectors with BNC loophrough connectors
 Video Standard: PAL or NTSC (auto selected)
 Video Bandwidth: 150Mhz
 Video Crosstalk: <70dB up to 10MHz
 Sync: Automatically either Channel 1 or 'Sync' input
 Impedance: 75 Ohm self-terminating
 Routing: 8x4 Video Matrix
 Video outputs: 4 x 75Ohm Composite Video Outputs on BNC connectors
 Audio Inputs (SW9016/SW9026): 16 Balanced Audio inputs on Phoenix/Combicon removable screw connectors.
 Routing: 16x8 Audio Matrix, each channel independently addressable
 Input Impedance: 10kOhm
 Maximum Input Level: +20dBu
 THD: <0.02%

Control Ports (All devices)

Control input voltage: 0 to 4.5v
 Control input impedance (2 wire): 4.7kOhms to +5V
 Control input impedance (3 wire): >1mOhm
 Logic output voltage: 0 or +5v unloaded
 Logic output impedance: 440 Ohms
 Opto. output current: 14mA max
 Opto. output withstanding voltage: 80V max
 Opto. output series impedance: 220 Ohms (isolated)

Network (9000iis, 9088iis, 9008iis)

Maximum network cable length: 300m/1000ft between any two devices

Power & Dimensions (9000iis, 9088iis, 9008iis, 3088)

Mains supply: Integral multi-voltage switching PSU, 85-270V AC, 50/60Hz
 Power consumption: <35VA
 Dimensions (h (U) x w x d): 1.75" (1U) x 19" x 11.3" (45mm x 483mm x 287mm)
 Weight: 6.6lbs (3kgs)

Soundweb 9010 Programmable Controller

Mic Input: 18 Bit A/D Conversion
 External Input Specifications
 Dynamic Range: 81dB (22Hz to 22kHz unweighted)
 Gain Control Range: 34dB to 72.5dB
 Max Input Level: -17dBu
 EIN: -106dBu @ 150 Ohm
 Audio Output: 18 Bit D/A Conversion
 Dynamic Range: >88dB (22Hz to 22kHz unweighted)
 Frequency Response: 30Hz to 20kHz, +0/-0.5dB
 THD: <0.05% (20Hz-20kHz, 0dBu)
 Max Output Level: +4dBu
 Channel Separation: 80dB, 20Hz-20kHz
 Power Requirements: +24V DC, <5VA

Frequency Response: 20Hz-20kHz +0/-0.2dB
 S/N Ratio: >110dB at unity gain
 Crosstalk: <-100dB
 CMRR: >40dB
 Audio Outputs: 8 Balanced Audio Outputs on Phoenix/Combicon removable screw connectors.
 Output gain: adjustable, -inf to +20dB

Control & Presets

Presets: 8 presets per video output zone when used with standalone PC app
 Serial Control Port: RS232 connects to Soundweb 9088iis,9008iis 3088, 9000iis or PC

Dimensions (h (U) x w x d):

SW9016: 3.5" (2U) x 19" x 6.6" (89mm x 445mm x 168mm)
 SW9026: 1.75" (1U) x 19" x 6.6" (44.5mm x 445mm x 168mm)
 Weight SW9016: 3kgs (6.6lbs)
 SW9026: 2.3kgs (5.3lbs)

SW9014 — Fibre Interface

Power
 DC Supply: 12-24V DC, <5VA Connector: Phoenix screw terminal or 2.4mm inline barrel connector
 Network: Single RJ-45 Can be input node or output node - auto-sensed (no setup required)
 Fibre Connections: Snap-in SC fibre input, Snap-in SC fibre output
 Fibre cable: Multimode 62.5/125um, or Multimode 50/125um
 Optical Power Budget: 10dB
 Indicators: Power led, Fibre Link Active led, Network cable present led
 Max fibre length: 2,000 metres/6,550 feet/1.2 miles
 Dimensions (h x w x d): 1.4" x 5.3" x 5.5" (36mm x 135mm x 139mm)

Three 9014 devices can be mounted side-by-side in a 1U panel (available from BSS Audio). The panel can be used to rackmount a single or two 9014 devices if required, and can be fitted with the Z-999-PSU in this case.

BSS Audio offer a universal AC input +24V DC power supply (Z-999-PSU) for the 9010 and 9014 devices and an interface adapter for the 9010(Z-SW9011). The PSU may connect directly to an SW9010, or connect via the Interface adapter where power will be supplied via the network.

BSS Audio reserves the right to change product designs and specifications without notice in the interest of product development. E&OE
 This product is designed and produced by BSS Audio, England
 All trademarks acknowledged. All use of client photographs and images within this publication is gratefully acknowledged.

BSS Audio

A Division of Harman International Industries Ltd.
 Cranborne House, Cranborne Road, Potters Bar, Herts, England EN6 3JN
 Tel: +44 (0)1707 660667 Fax: +44 (0)1707 660755
 e-mail: info@bss.co.uk www.bss.co.uk

BSS Audio USA

The Harman Music Group
 8760 S. Sandy Parkway, Sandy, Utah 84070, USA
 Telephone: 801-566-8800 • Fax: 801-566-7662
 web: www.bssaudio.com
 e-mail: BSSAudioUSA@harman.com

